

The Xi2 System (2024 Version) Instructions use the Lateral and Longitudinal struts to replace normal lateral frame tie and longitudinal end tie anchorage and stabilizer plates. The home manufacturer may require additional vertical anchor ties that are unique to a home's design. Check the manufacturers installation instructions for set-up requirements.

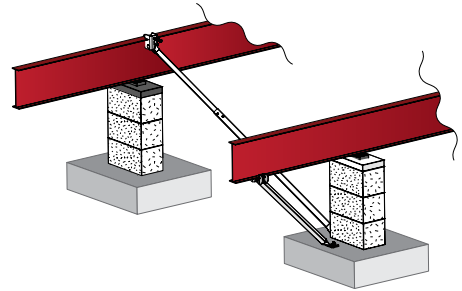

### Installation Requirements

- Install in any type soil, 4B (175-275 lbs.) or better.
- Main rail spacing must be 75.5" – 99.5", 112" exception with proper strut.
- Maximum pier height at system 48", with 6" maximum rise from location of system to end of home. For all other piers use the home manufacturers set up instructions.
- Maximum vertical projection at sidewall is 9' wall and roof rim (9' wall and 12" eave). Higher walls may be used, when possible for design loads to be adjusted accordingly. For 10' walls, check with Tie Down.
- Longitudinal strut angle no more than 50 degrees and no less than 25 degrees. The longitudinal component of the Xi2 system replaces end frame ties. Check manufacturers requirements.
- For roof slopes greater than 20 degrees, (4.37" in 12" pitch) see page 3.
- Two systems designed to work with each other must be placed as evenly as possible. Measuring from the center of the block/pier, systems are to be placed a minimum of 2' to a recommended maximum of 10' (when needed may be a maximum of 1/4 the length of the home) from each end of home as shown on pier placement chart. Components of the Xi2 system such as the longitudinal strut and connecting hardware, may extend beyond pier location and can face in or out as long as both systems share the same direction, both either facing in or both facing out.
- This System only replaces normal lateral frame tie and or longitudinal end tie anchorage. Wind Zones II and III (100+ mph) require vertical sidewall anchorage for high wind areas. The home manufacturer may require additional vertical anchor ties that are unique to the home's design. These locations may include shear walls, marriage line ridge beam supports, and rim plates. Check the manufacturer's installation instructions for set-up requirements.
- Additional Requirement for Concrete (on following page)

Xi2-24 components exceed HUD code 3280.306 g "Anchoring equipment exposed to weathering shall have a resistance to weather deterioration at least equivalent to that provided by a coating of zinc on steel of not less than 0.30 ounces per square foot of surface coated. The Xi2-24 Foundation System by Tie Down complies with 24CFR Part 3280 & 3285 when installed in accordance with the instructions provided by Tie Down.



Up To Date/Expanded  
Concrete & Ground  
Installation Manual



Instruction #08462 (D2043 - Rev. 5/28/24)

## Concrete Requirements

- Poured concrete must be 2500 PSI minimum at 28 days. Bottom of footers must be below the frost line or a minimum of 4" below finished grade. Check with authorities for local requirements (LAHJ).
- **Footer Requirement:** Must be large enough for the pier load at that location and be a minimum of 22" wide by 6" deep with anchor wedge bolts a minimum of 4" from any edge or 18" wide by 12" deep with anchor wedge bolts a minimum of 1-1/2" from edge. Strip footings minimum of 18" wide by 14' long by 6" deep or 27" wide by 14' long by 4" deep.

## Xi2 Lateral Stabilization

Approved Anchor\*  
with strap from  
45 to 90 degrees

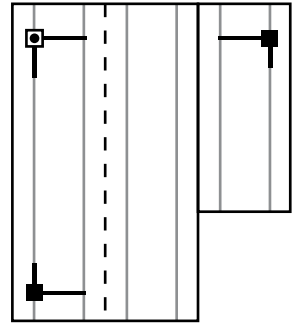
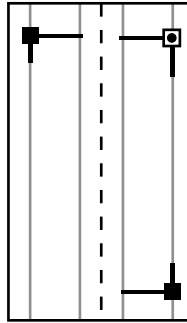
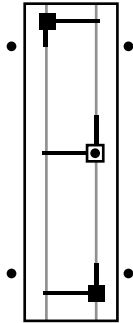

### Wind Zones I & II

**Single Section Home**  
0 - 76' Box 2 Xi2 Systems  
Over 76' Box 3 Xi2 Systems

**Double Section Home**  
0 - 76' Box 2 Xi2 Systems  
Over 76' Box 3 Xi2 Systems

**Triple Section Home**  
0 - 76' Box 2 Xi2 Systems  
Over 76' Box 3 Xi2 Systems

### Wind Zones III

**Single Section Home**  
0 - 64' Box 2 Xi2 Systems  
Over 64' Box 3 Xi2 Systems

**Double Section Home**  
0 - 64' Box 2 Xi2 Systems  
Over 64' Box 3 Xi2 Systems

**Triple Section Home**  
0 - 64' Box 2 Xi2 Systems  
Over 64' Box 3 Xi2 Systems

\* For Wind Zone I - approved uplift anchor and strap from 45 to 90 degrees, within 10' of end of home on single sections. Anchors within 2' of end in Missouri.

**NOTE:** Diagram represents single section up to 16' width, double section up to 32' width, and triple section homes up to 48' width.

**Alternative Footing Anchoring Method\*:** Poured concrete footings 18" X 18" X 48" deep can have the anchors installed on the 4 corners within 10" of the end of the home. Footings less than 48" deep require a minimum of 18" X 18" X 12" deep (Check for local minimum frost line depth requirements) with an anchor on all 4 of the corners and 1 in the middle on each side for a total of 6. Anchors would be installed in the footings with straps installed vertically, replacing the frame ties.

\*Alternative Footing Anchoring Method NOT Approved in Missouri.

Note: Diagram represents single section up to 16' width, double section up to 32' width, and triple section up to 48' width.

## Xi2 Longitudinal Stabilization for Wind Zones II & III

When using longitudinal stabilization only, in higher wind zones, Systems must be spaced as evenly as possible, no more than 10' from the end of the home. Longitudinal Struts DO NOT replace anchors on single section homes.

**NOTE:** On triple section homes in WZ II & III an additional longitudinal system is required. It should be installed on the center section.

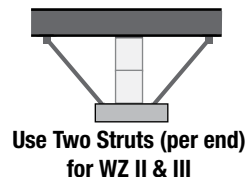
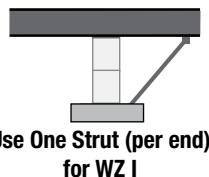

## Xi2-24 System Requirements for Roof Pitches Higher than 20 degrees

### Additional Systems:

On a single section home, the 3rd system is placed in the middle of the home. When using 3 or 4 systems (double and triple sections), install on opposite corners. If needed, a 5th system would be in the center of the unit on either side.

Length (Feet)	Wind Zone I				Wind Zone II				Wind Zone III			
	5:12	6:12	7:12	9:12	5:12	6:12	7:12	9:12	5:12	6:12	7:12	9:12
34	2	2	2	2	2	2	2	2	2	2	3	3
36	2	2	2	2	2	2	2	3	2	2	3	3
38	2	2	2	3	2	2	2	3	2	3	3	3
40	2	2	2	3	2	2	2	3	3	3	3	3
42	2	2	3	3	2	2	3	3	3	3	3	3
44	2	2	3	3	2	2	3	3	3	3	3	3
46	2	3	3	3	2	3	3	3	3	3	3	4
48	2	3	3	3	3	3	3	3	3	3	3	4
50	3	3	3	3	3	3	3	3	3	3	3	4
52	3	3	3	3	3	3	3	3	3	3	4	4
54	3	3	3	3	3	3	3	3	3	3	4	4
56	3	3	3	3	3	3	3	3	3	3	4	4
58	3	3	3	3	3	3	3	3	3	3	4	4
60	3	3	3	3	3	3	3	3	3	3	4	5
62	3	3	3	3	3	3	3	3	4	4	4	5
64	3	3	4	4	3	3	4	4	4	4	4	5
66	3	3	4	4	3	3	4	4	4	4	4	5
68	3	4	4	4	3	4	4	4	4	4	5	5
70	3	4	4	4	3	4	4	4	4	4	5	5
72	3	4	4	4	4	4	4	5	4	4	5	5
74	4	4	4	5	4	4	4	5	4	5	5	5
76	4	4	4	5	4	4	4	5	4	5	5	6
78	4	4	4	5	4	4	4	5	4	5	5	6
80	4	4	4	5	4	4	4	5	4	5	5	6

## Xi2-24 Foundation System Installation for Concrete

### Step 1 – Concrete Footer

- Build footer according to State Local, or Home Manufacturer’s guidelines.
- **For Dry Set:** Depending on depth of footer, measure 1 1/2” from edge or 4” from edge of footer and drill a 1/2” x 3” hole on the side of the block under the beam for longitudinal and a hole at the end of the block for the lateral going across to the other beam. Place a nut and washer on the very top of anchor wedge bolt leaving no threads showing. Using a hammer, tap the bolts until snug in the hole, remove nut and washer and attach strut and pan washer to anchor bolt, followed by the washer and nut. Tighten wedge bolt to slab.
- **Note: Once the wedge bolts are set, proceed with standard installation steps.**
- **For Wet Set:** Follow steps for dry set except instead of drilling a hole in the footing insert the J bolt into the wet concrete up to the bottom of the threads at the proper placement and allow to dry.

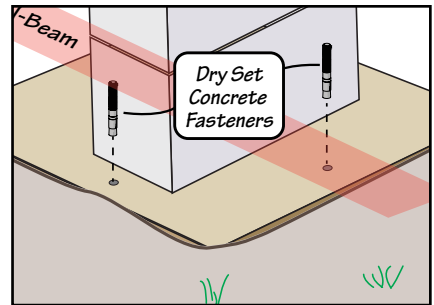

Fig. 3-2

### Step 2 - Longitudinal Beam Clamps

- Position two longitudinal beam clamps on both sides of the I-beam. The I-beam frame will slide into the slot on the clamp.
- Raise the longitudinal strut upward and position it between the two beam brackets as shown right in Fig. 3-3.
- Insert a 4” carriage bolt through the clamp, strut, and opposite clamp as shown right.
- Attach a flange nut to the carriage bolt. Note: the two “loose” beam clamps will appear to be out of alignment with the frame.
- Do Not tighten beam clamps.

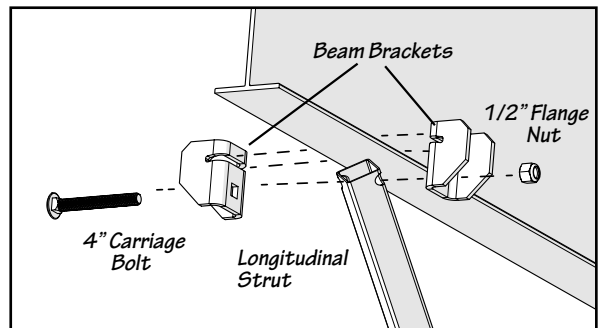

Fig. 3-3

### Step 3 - Longitudinal Strut

- Slide the end of the longitudinal strut over the wedge bolt on the footer.
  - Slide a pan washer over the wedge bolt, install a flange nut over the wedge bolt as show right in Fig. 4-1
  - Using a 3/4" deep socket/impact driver, tighten the flange nut on the footer.
  - Pull outward on the longitudinal beam clamp removing any slack between the clamp and ground pad.
  - Using a 3/4" deep socket/impact driver, tighten the flange nut on the beam clamp.
- Note: As the bolt/nut tighten, the two beam clamps will begin to crimp the I-beam.

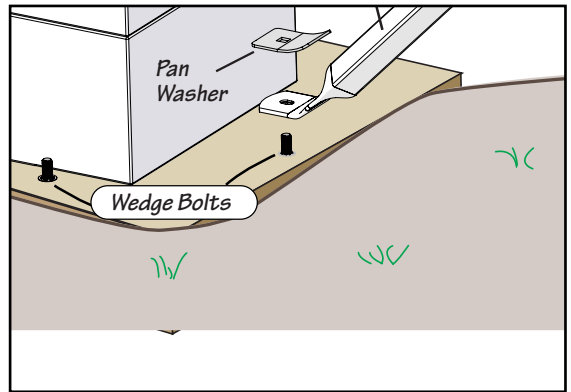

Fig. 4-1

### Step 4 - Lateral Strut Beam Attachment

- Extend the lateral strut outward to the opposite side I-beam.
- NOTE: The fully extended strut must maintain a minimum 6" to 8" overlap between inner and outer tubes.**
- Slide the "J" bolt over the I-beam and between the home frame.
  - Slide the beam clamp over the "J" bolt end passing through the top of the beam clamp and slide the clamp over the i-beam frame as shown in Fig. 4-2. Attach flange nut over the "J" bolt and loosely tighten nut.
  - Align/insert the lateral strut end in the mounting slot on the bottom of the beam clamp as shown in Fig. 4-2.
  - Pass a carriage bolt through the beam clamp and lateral strut coming out the opposite side beam clamp. Loosely tighten flange nut. Do not tighten nut.
  - Slide the assembled beam clamp with the mounted lateral strut left or right aligning the strut perpendicular to the pad.
  - Once the beam clamp/strut attachment is in its final location, tighten the two flange nuts.

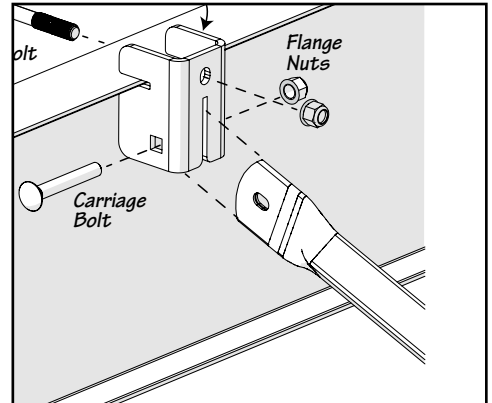

Fig. 4-2

### Step 5 - Lateral Strut Base Attachment

- Slide the end of the lateral strut over the carriage bolt on the ground pad.
- Slide a pan washer over the carriage bolt/lateral strut, install a flange nut over the carriage bolt as show right in Fig. 4-3.
- Using a 3/4" deep socket/impact driver, tighten the flange nut on the ground pad.
- Using a 3/4" deep socket/impact driver, tighten the flange nut on the beam clamp.

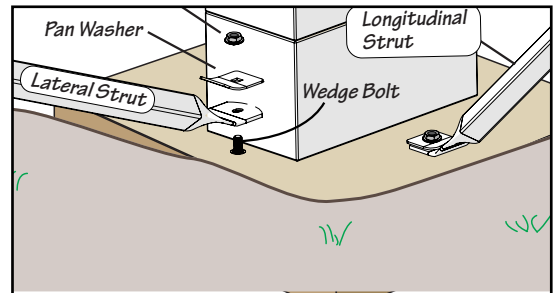

Fig. 4-3

### Step 6 - Strut Fasteners

- Secure the extended lateral strut by mounting 4 self tapping screws in the 4 holes in the outer lateral tube as shown in Fig. 4-4. Attach two screws per side.

Lateral Strut Beam Attachment

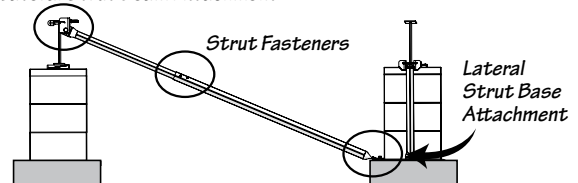

Fig. 4-4